

## 6 ASSEMBLY INSTRUCTIONS

### 6.5.2 With surface mounting

For surface mounting, pipes are available in straight lengths for the sake of convenience. Pipe brackets must be used when fixing Henco multilayer pipes to the **wall or ceiling**. The suspension brackets are synthetic or metal with a synthetic ring for the protection of the pipe. The specified maximum distance between the brackets must be adhered. The adjacent table gives an overview of the bracket distances to be kept.

Pipe	Max. distance pipe brackets (cm)
14 x 2	80
16 x 2	80
18 x 2	100
20 x 2	120
26 x 3	150
32 x 3	160
40 x 3,5	170
50 x 4	180
63 x 4,5	200

The **pipe brackets** have a twofold purpose; firstly they support the pipe network, and secondly they accommodate the thermal length changes of the pipe with **sliding and fixed points**, usually in combination with correctly calculated expansion bends and expansion loops. The sliding points must be such that the pipe continuously has clearance. The sliding point may not become a fixed point when the pipe expands.

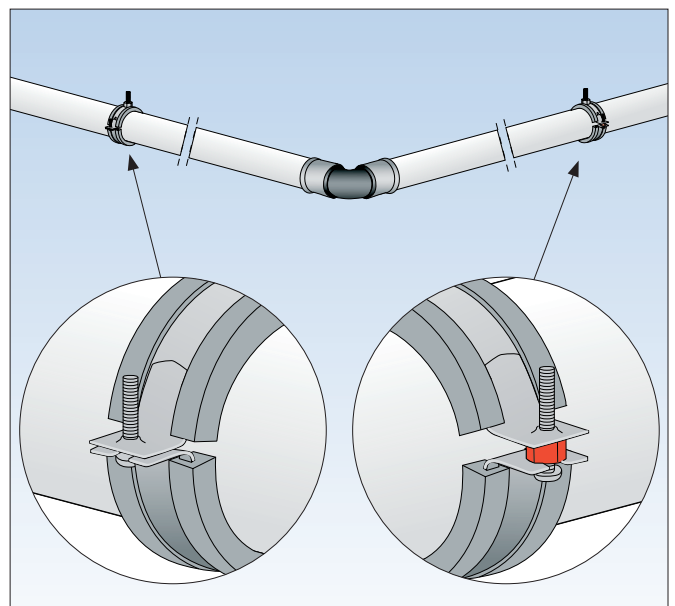
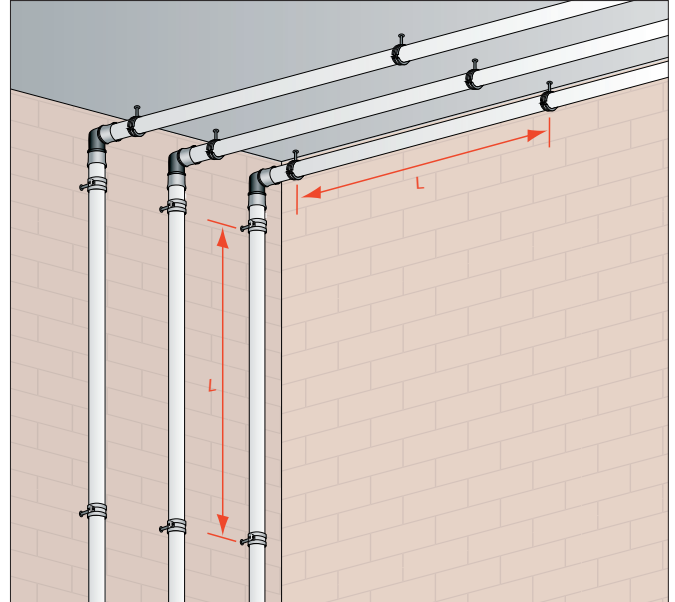



The correct placing of sliding points and fixed points is very important when expansion bends and expansion loops are used. At all changes in direction expansion bends must be provided.

For making direction changes it is recommended to always use fittings. For pipes with a diameter of 32 mm or greater this is compulsory.

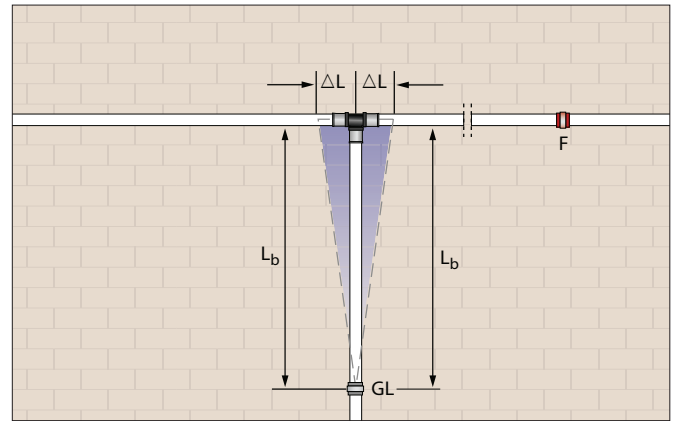
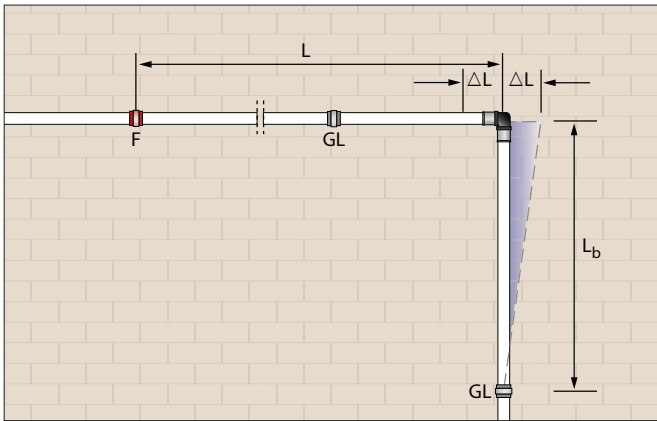

- $L$  = length of the pipe
- $L_b$  = length of the expansion bend
- $\Delta L$  = change in length
- $F$  = fixed point
- $GL$  = sliding point
- Expansion bend for  $r L (L_b)$

**When a long pipe does not change direction expansion loops are required.**

An **expansion loop** is also called a lyra or omega bend. The drawing below clarifies what an expansion loop is.

The expansion loop is in principle formed by two expansion bends. A fixed point must therefore be provided at the bottom in the middle of the loop.

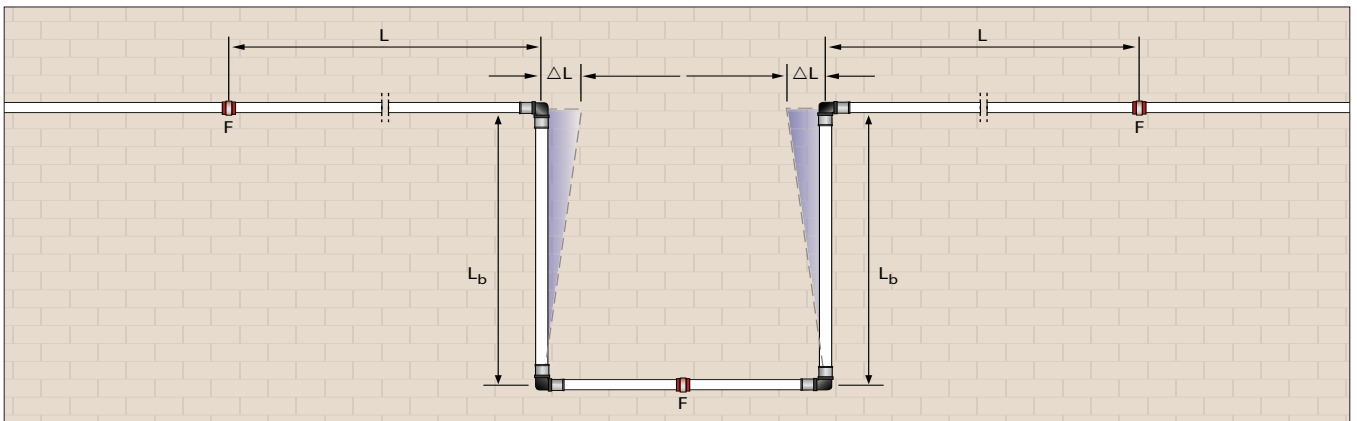

- 1
- 2
- 3
- 4
- 5
- 6
- 7
- 8
- 9
- 10
- 11
- 12
- 13

# 6 ASSEMBLY INSTRUCTIONS

The minimum length of the expansion bend can be calculated on the basis of the following formula or read from the diagram below:

$$L_b = C \times \sqrt{(D \times \Delta L)}$$

with: **L<sub>b</sub>** = length of the expansion bend  
**C** = material constant (=33)  
**D** = outside diameter of the pipe  
**ΔL** = change in length

*Example:*

Given:  $L = 4 \text{ m}$   
 $D = 26 \text{ mm}$   
 $\Delta T = 50^\circ\text{C}$  ( $T_{\text{min}}=10^\circ\text{C}$  en  $T_{\text{max}}= 60^\circ\text{C}$ )

Asked:  $L_b$

Solution:  $L_b = C \times \sqrt{(D \times \Delta L)}$   
 with  $\Delta L = L \times \alpha \times \Delta T$   
 $= 4 \times 0,025 \times 50$   
 $= 5 \text{ mm}$   
 $L_b = C \times \sqrt{(D \times \Delta L)}$   
 $= 33 \times \sqrt{26 \times 5}$   
 $= 376,25 \text{ mm}$

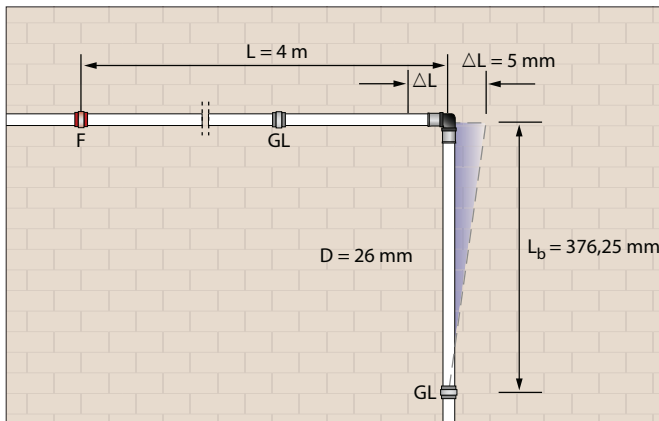

For a pipe with a diameter of 26 mm and a length of 4 m that has a change of direction, with a temperature difference of 50°C an expansion bend of 376.25 mm will have to be provided to accommodate the change in length.

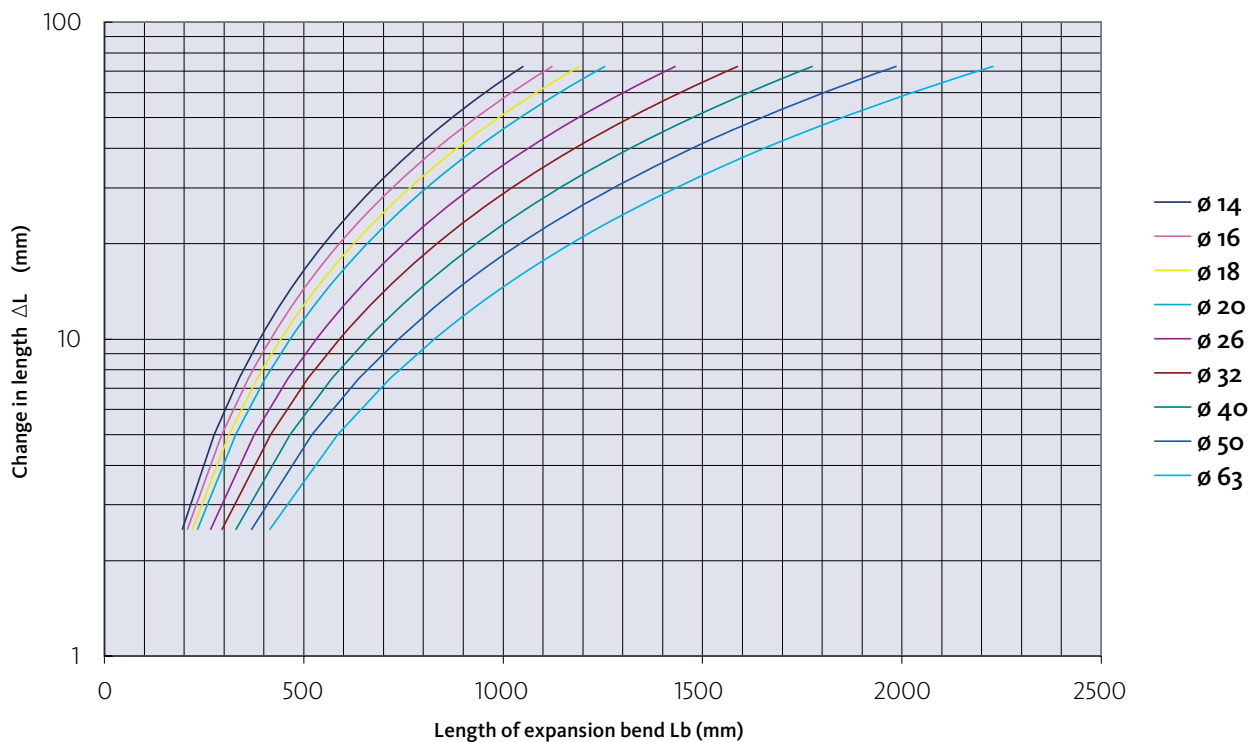



It must also be ensured that pipes can freely move **when piping runs from floors to a riser pipe in a shaft**. Also here, the change in length can be accommodated by an expansion bend. The expansion bend will then accommodate the upward and downward movements.

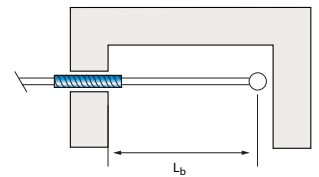
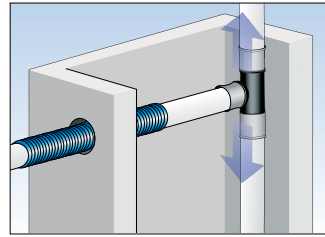

If the shaft is large enough and there is space to fit the calculated expansion bend, it suffices to give the pipe a protective sleeve at the hole in the wall.

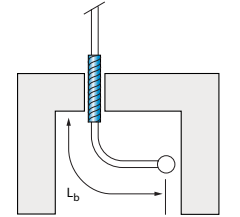
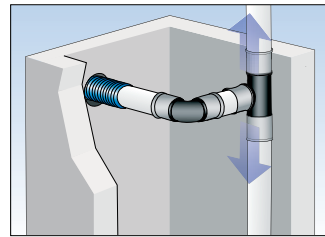

If the shaft is too small to fit the calculated expansion bend, the hole in the wall will have to be made larger to give the pipe sufficient room for movement. The pipe must be provided at the hole in the wall with PE insulation.

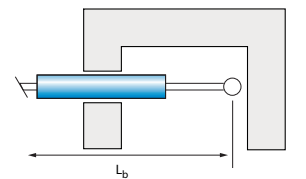
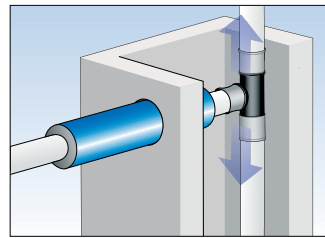

For installations where Henco multilayer pipes are laid **straight on floor**, a fixing distance applies of max. 80 cm. Before and after a 90° bend, fixing by pipe brackets must be provided at 30 cm.

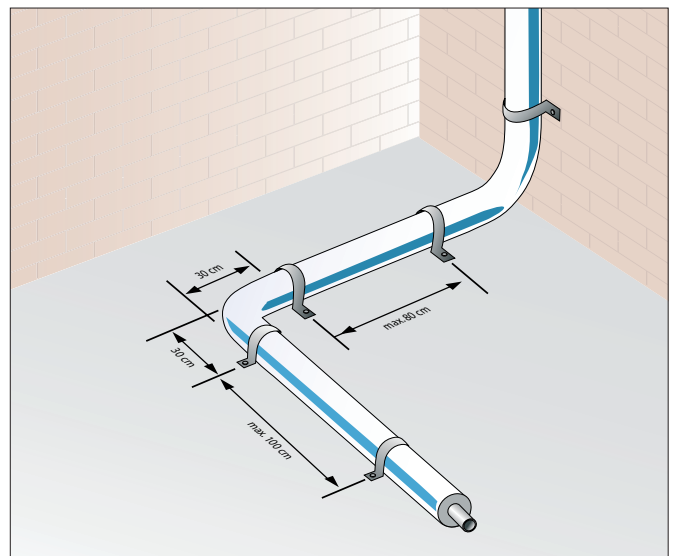

- 1
- 2
- 3
- 4
- 5
- 6
- 7
- 8
- 9
- 10
- 11
- 12
- 13

# 6 ASSEMBLY INSTRUCTIONS

- 1
- 2
- 3
- 4
- 5
- 6
- 7
- 8
- 9
- 10
- 11
- 12
- 13

If the riser pipe is longer than 10 m a fixed point must always be provided. It is recommended to have this point in the middle of the pipe because then the expansion forces generated will be smaller.

The drawings show that the total length of the expansion bends one must provide if one has the fixed point in the middle of the riser pipe it is much less than when one has the fixed point at the start of the riser pipe.

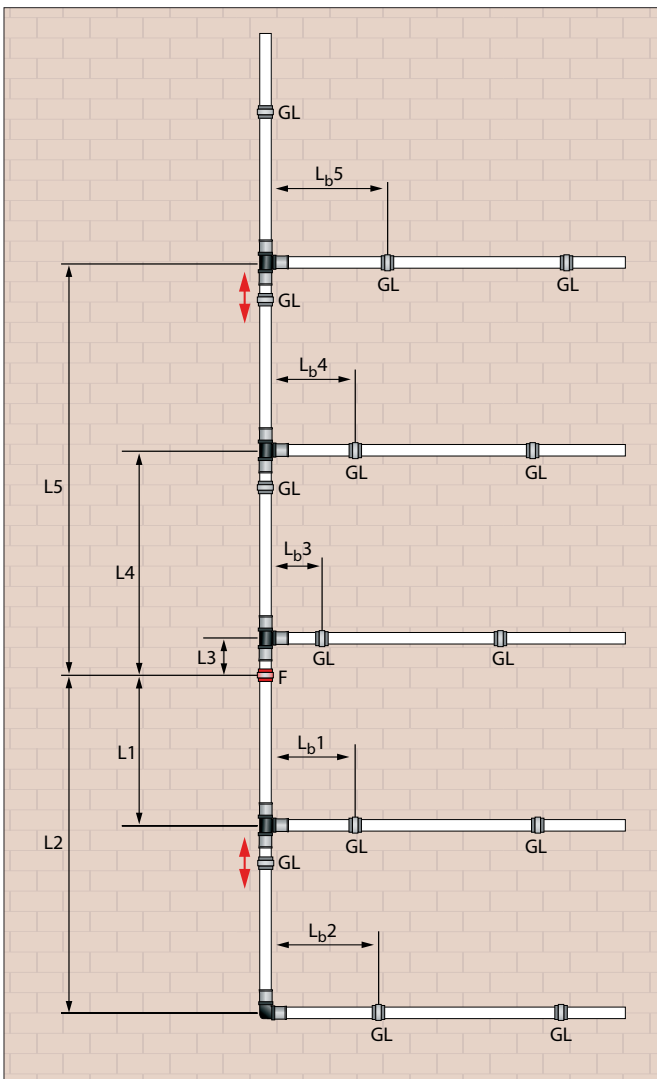

$$L_{b1} + L_{b2} + L_{b3} + L_{b4} + L_{b5}$$

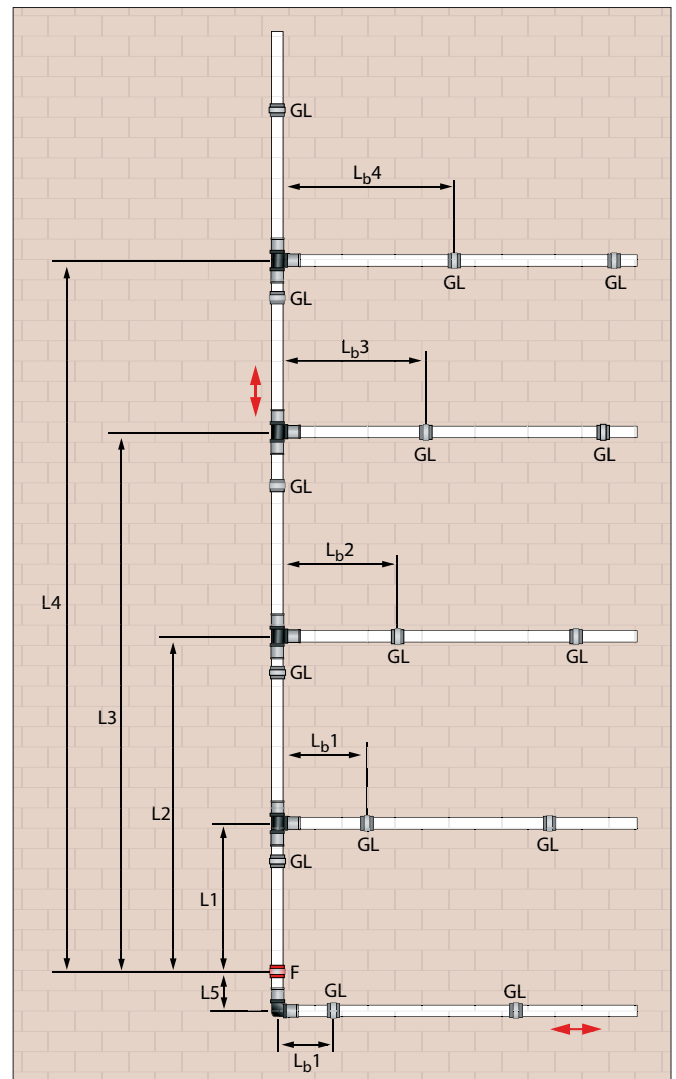

$$L_{b1} + L_{b2} + L_{b3} + L_{b4} + L_{b5}$$